

Series 2A 1969 petrol (headlights in the wings)

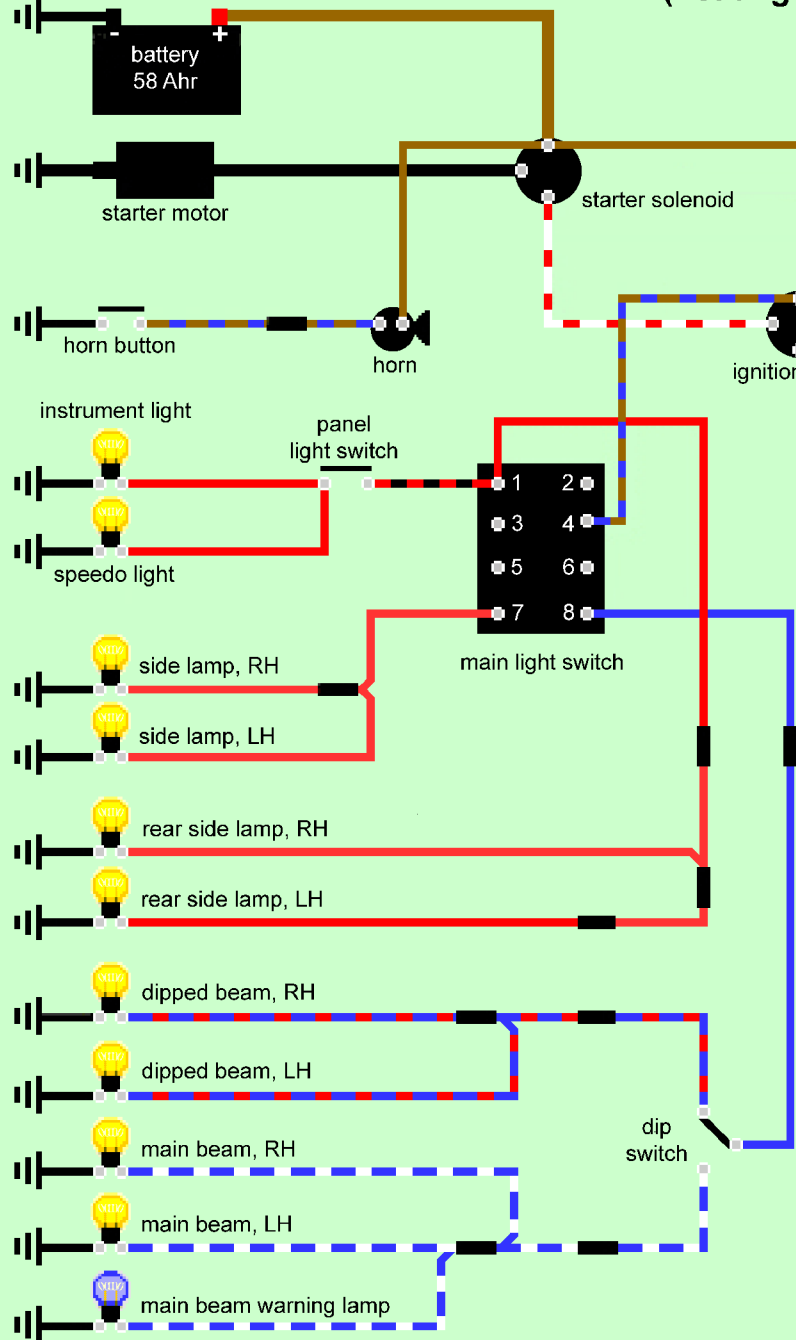

Bulb Data

Headlamps with separate bulbs
Lucas 414, 50/40w, GLB414

Sealed beam units, Lucas 104,60/45w, GLU104
Halogen conversion Lucas 472 H4

Side lamps, Lucas 207, 12v 6w, GLB207

Stop/tail lamps, Lucas 380, 12v 21/6w, GLB380

Flasher lamps, Lucas 382, 12v 21w, GLB382

Rear number plate lamp, Lucas 989, 12v 6w, GLB989

Instrument panel lamps, Lucas 987, 12v 2.2w MES, GLB987

Warning lamps, Lucas 987, 12v 2.2w MES, GLB987

Flasher warning lamp, Magnatex GBP 12v 2.2 w, GLB643

Interior lamp, Lucas 382, 12v 21w, GLB382

(Warning lamp - Diesel heater plugs, Lucas 982, 6v 1.8w, GLB982)

(Warning lamp - Diesel low fuel, LR 580756 mini lamp 12/14v 0.04A)

Correct for UK lighting regulations, check for use in other countries.

